

URBE
▶▶▶▶
ADAPTA

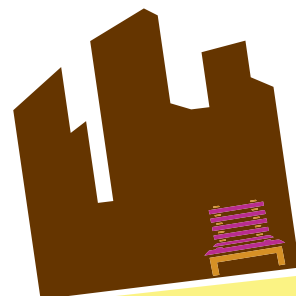

bancos

Ref: UAM1011

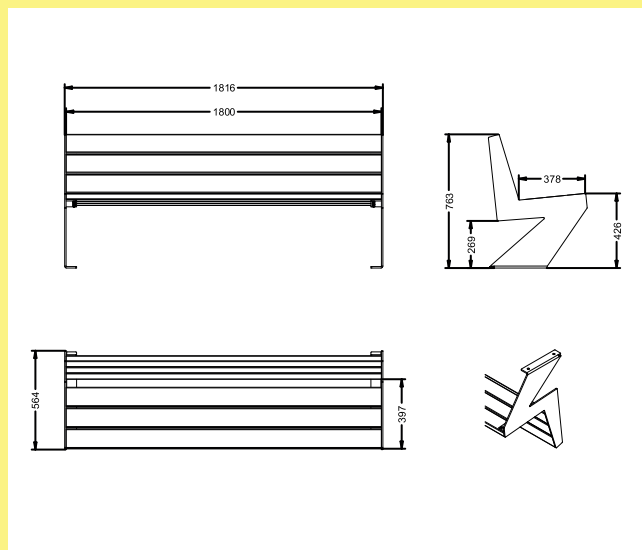

PIE: Acero pintado en plata.

LISTONES (5): Madera de Guinea tratada, de 35 mm de espesor y barnizada con lasur a poro abierto.

TORNILLERIA: Tornillo M10x100.

ANCHO: 1816 mm

LARGO: 564 mm

ALTO: 783 mm



comercial@urbeadapta.com TELF: 661 534 251