

## señalización

### PANEL ATRIL

Ref: UAS1107

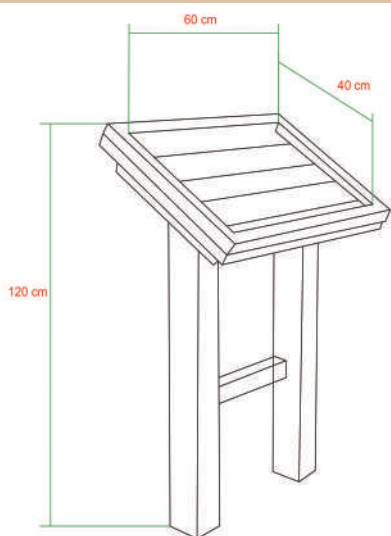

**MATERIALES:** Madera de pino tratado en autoclave nivel IV.

**MEDIDAS ATRIL:** 60x 40 cm

**MEDIDAS TOTAL ALTURA:** 120 cm

**PESO (APROX.):** 30 kg

**UNIONES:** Tornillería en acero galvanizado.

