

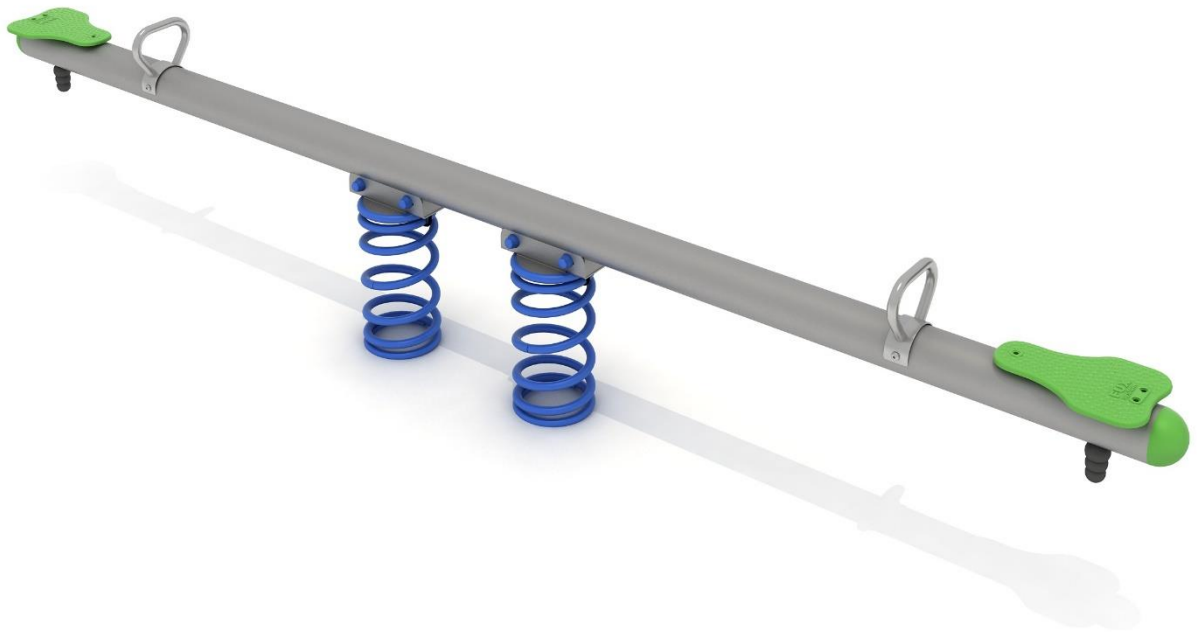

FUX SYSTEM

PZ.244 Dragonfly single swing on the springs

Swing for two children from the age of 3 years. Rubber seat with green aluminum insert placed on a movable structure. Support elements made of galvanized steel powder coated in silver. The finishing elements may differ from presented in the visualization.





FUX SYSTEM

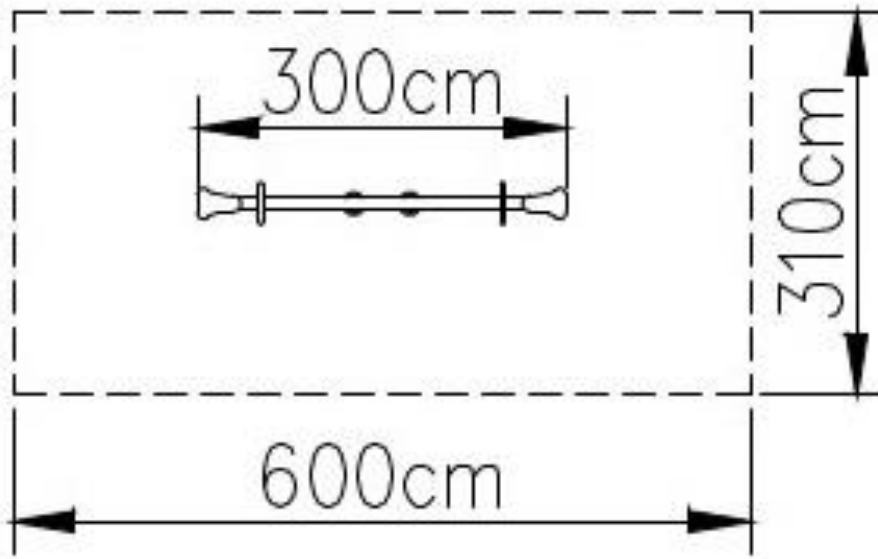

Technical data:

- length: 300 cm
- width: 40 cm
- height: 80 cm
- free fall height: 120 cm
- fall zone: 600 x 310 cm
- safety standards EN 1176-1; EN 1176-6, PN-EN 1176-7
- age range: 5-12 years

Materials:

- Metal parts made of powder-coated galvanized steel,
- finishing elements (seats) rubber with an aluminum insert

Security:

- galvanized steel powder coated.